



6V Series solenoid valve (5/2 way, 5/3 way)

Compendium of 6V Series

Multi-port types are optional

Threaded type and quick connector type are optional, and can integrate manifold to form valve group to save space.

Inner exhaust structure

Pilot airflow exhaust intensively from R, S port.

Terminal

Special design for terminal, horizontal and vertical insertion can freely switch.



Multi-series and type

6V0500, 6V100, 6V200, 6V300 series are optional.

Die-cast molding with aluminum alloy for body

Internal hole adopts special processing technology which has little attrition friction, low start pressure and long service life.

Installation and Application

1. Don't throw or drop the solenoid valve when take it, to avoid breaking valve;
2. Because solenoid pilot valve is sophisticated component, can't crash pilot valve by outside force, otherwise solenoid valve break possibly;
3. Don't dismantle solenoid valve freely, if the screw(M1.6X14) becomes loose, please tighten it by torque 0.1~0.12N.m;
4. About manual operation:

4.1. Ensure no danger, prior to activating manual override;

4.2. For push button option:

Activate by push the button in the direction shown

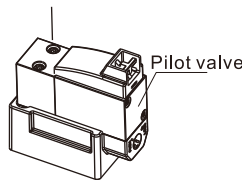

4.3. For slotted option:

Activate by push the button in the direction shown.

With correct size screw driver: please turn to lock gently(Torque: 0.1N.m).

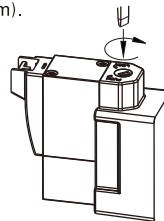

Attention

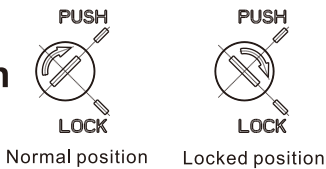

4.4. Wiring instruction: Vertical plug type and parallel plug type are the same as plug, please insert wire line as up drawing by practicality.



Vertical plug wire



Parallel plug wire



Solenoid valve (5/2 way, 5/3 way)

6V Series



Symbol

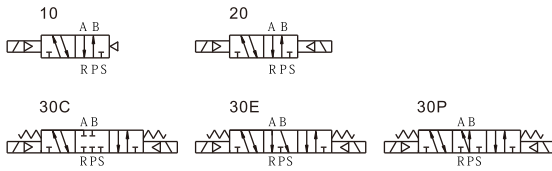

Specification

Model	6V0510	6V0520	6V0530	6V110	6V120	6V130
Port size [Note1]	Thread type In=Out=Exh=M5			In=Out=Exh=M5(or=1/8")		
	Tube type A port=B port=Φ4			A port=B port=Φ4 (or=Φ6) (or=Φ8)		
Orifice size(Cv) [Note4]	M5:3.4mm ² (0.2)		6V0530CM5: 2.2mm ² (0.13)	06:8.9mm ² (0.52)		6V130C06: 8.0mm ² (0.47)
Weight	35g	50g	65g	60g	75g	90g
Model	6V210	6V220	6V230	6V310	6V320	6V330
Port size [Note1]	Thread type In=Out=1/8"(or=1/4")Exh=1/8"			In=Out=3/8" Exh=1/4"		
	Tube type A port=B port=Φ6(or=Φ8) (or=Φ10)			-		
Orifice size(Cv) [Note4]	08:15.4mm ² (0.91)		6V230C08: 14.2mm ² (0.84)	10:38.4mm ² (2.26)		6V330C10: 30.5mm ² (1.8)
Weight	100g	115g	130g	230g	265g	305g
Fluid	Air(to be filtered by 40 μm filter element)					
Acting	Internal pilot					
Operating pressure	5/3 way		0.2~0.8MPa(29~114psi)			
	5/2 way		0.15~0.8MPa(21~114psi)			
Proof pressure	1.2MPa(175psi)					
Temperature	-20~70°C					
Material of body	Aluminum alloy					
Lubrication [Note3]	Not required					
Pilot valve's Exhaust type	Centralized exhaust type					
Max.frequency [Note2]	5 cycle/sec		3 cycle/sec		5 cycle/sec 3 cycle/sec	

[Note1] G thread is available.

[Note2] The maximum actuation frequency is in the no-load state.

[Note3] Once lubricated air is used, continue with same medium to optimize valve life span. Lubricants like ISO VG32 or equivalent are recommended.

[Note4] Equivalent orifice S and Cv are all calculated from the flow rate data.

Product feature

1. Electrical entry is terminal, horizontal and vertical insertion can freely switch.
2. Inner exhaust structure to collect pilot airflow, and then exhaust intensively from R, S port.
3. Internal hole adopts special processing technology which has little attrition friction, low start pressure and long service life.
4. Threaded type and quick connector type are optional, and can integrate manifold to form valve group to save space.

Coil specification

Item	Specification			
Standard voltage	AC220V	AC110V	DC24V	DC12V
Scope of voltage	AC: +15% ~-10%		DC: ±10%	
Power consumption	1.1VA		0.9W	
Protection	Dustproof			
Temperature classification	F Class			
Electrical entry	Terminal			
Activating time	0.05 sec and below			

Ordering code

6V 2 10 J 08 B 050 G

① ② ③ ④ ⑤ ⑥ ⑦ ⑧

① Model	6V: Solenoid valve (5/2, 5/3 way)							
② Code	05: 0500 Series	1: 100 Series		2: 200 Series		3: 300 Series		
③ Valve type	10: Single solenoid 5/2 way			20: Double solenoid 5/2 way				
	30C: Double solenoid 5/3 way closed center			30E: Double solenoid 5/3 way exhaust center				
	30P: Double solenoid 5/3 way pressure center							
④ Port type	Blank: Thread type J: Tube type							
⑤ Port size	Thread		M5: M5	M5: M5	06: 1/8"	06: 1/8"	08: 1/4"	10: 3/8"
	Tube		04: Φ4mm	04: Φ4mm/06: Φ6mm/08: Φ8mm	06: Φ6mm/08: Φ8mm/10: Φ10mm			
⑥ Voltage	A: AC220V		B: DC24V		C: AC110V		F: DC12V	
⑦ Line length	050: 0.5m			200: 2.0m				
⑧ Thread type [Note1]	-			G: G Thread				

[Note]: The base of the tube type solenoid valve is only used with the base.

Solenoid valve (5/2 way, 5/3 way)

6V Series

Flow chart

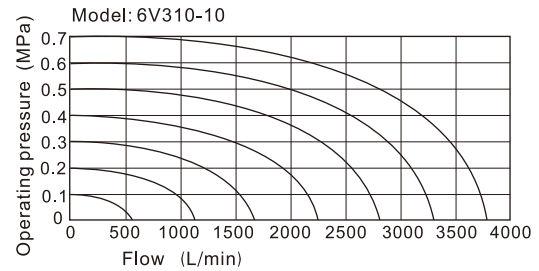
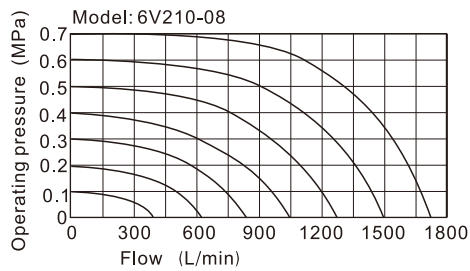
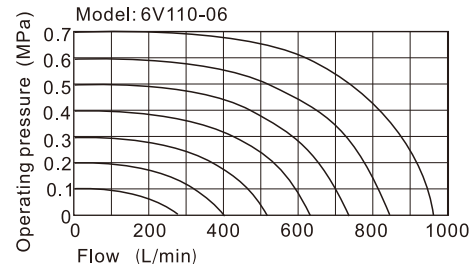
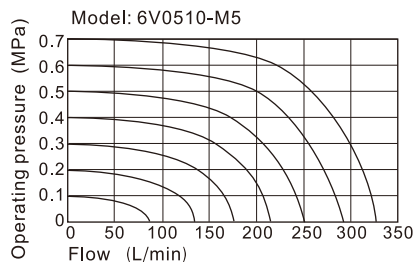

The data in flow rate chart are obtained from AirTAC lab.

Inner structure

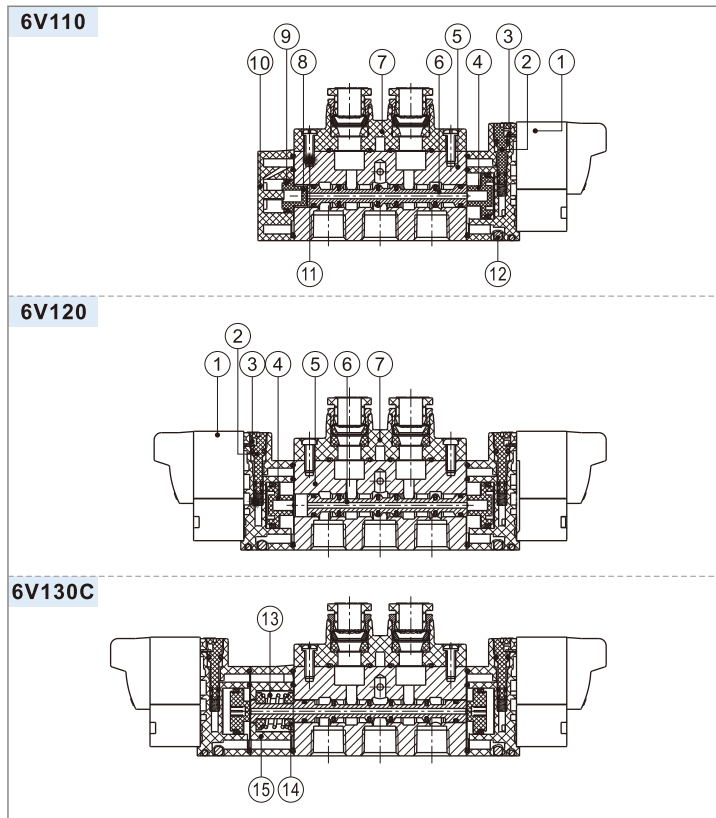

No.	Item	No.	Item	No.	Item
1	Pilot valve	6	Spool	11	Bolt
2	Manual override	7	Connecting block	12	Steel ball
3	Pilot kit	8	Little piston	13	Spring
4	Big piston	9	Gasket	14	Return holder
5	Body	10	Bottom cover	15	Side cover

Solenoid valve (5/2 way, 5/3 way)

6V Series

Dimensions

6V0510
6V110
6V210
6V310

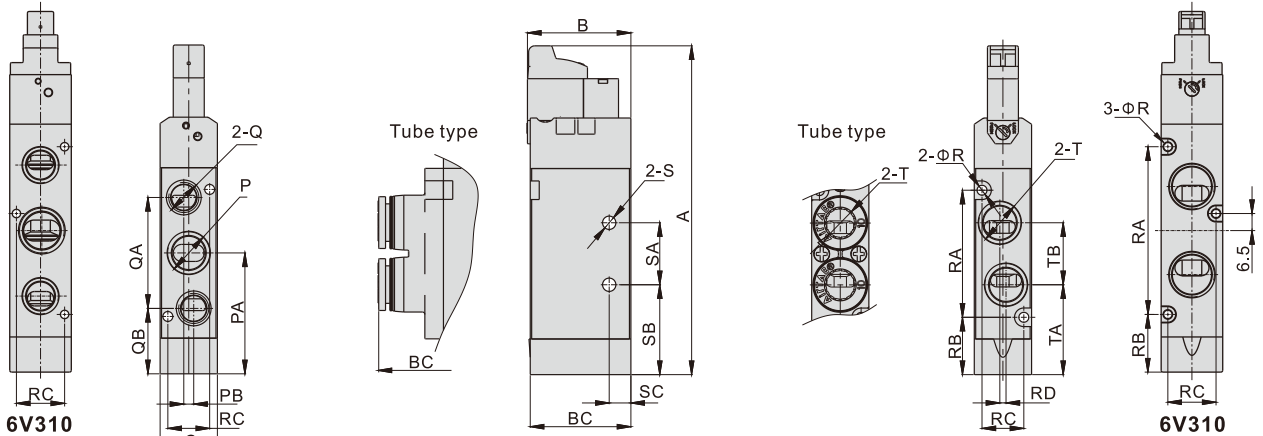

Model/Item	A	B	BC	C	P	PA	PB	Q	QA	QB	T	TA	TB	R	RA	RB	RC	RD	S	SA	SB	SC
6V0510M5	73	31	21	10.6	M5X0.8	22.5	1	M5X0.8	19	13	M5X0.8	17.5	10	2.1	22.5	11	7.5	0	Φ2.6	10	17.5	4
6V0510J04			Φ4(Tube)								-								-	-		
6V110M5	93.5	32	24	15.5	M5X0.8	33	2.6	1/8"	28	19	1/8"	24.5	16.5	2.6	34	16	11	0	Φ3.2	14	26	4
6V110J04			Φ4(Tube)								-								-	-		
6V110J06			41								Φ6(Tube)								-	-	-	
6V110J08			42.5								Φ8(Tube)								-	-	-	
6V21006	106	33.5	32.5	18.5	1/8"	39	3.2	1/8"	36	21	1/8"	29	20	3.2	41	18.5	13.5	2	Φ4.3	20	29	7
6V21008			1/4"								-								-	-		
6V210J06			50.6								Φ6(Tube)								-	-	-	
6V210J08			53.5								Φ8(Tube)								-	-	-	
6V210J10											Φ10(Tube)											
6V31010	137.5	46	46	23.5	3/8"	54	0.5	1/4"	50	29	3/8"	37	33.5	3.2	64	22	18.4	0	Φ4.3	25	41.5	8

[Note]: The base of the tube type solenoid valve is only used with the base. No through hole "S" on the side.

6V0520
6V120
6V220
6V320

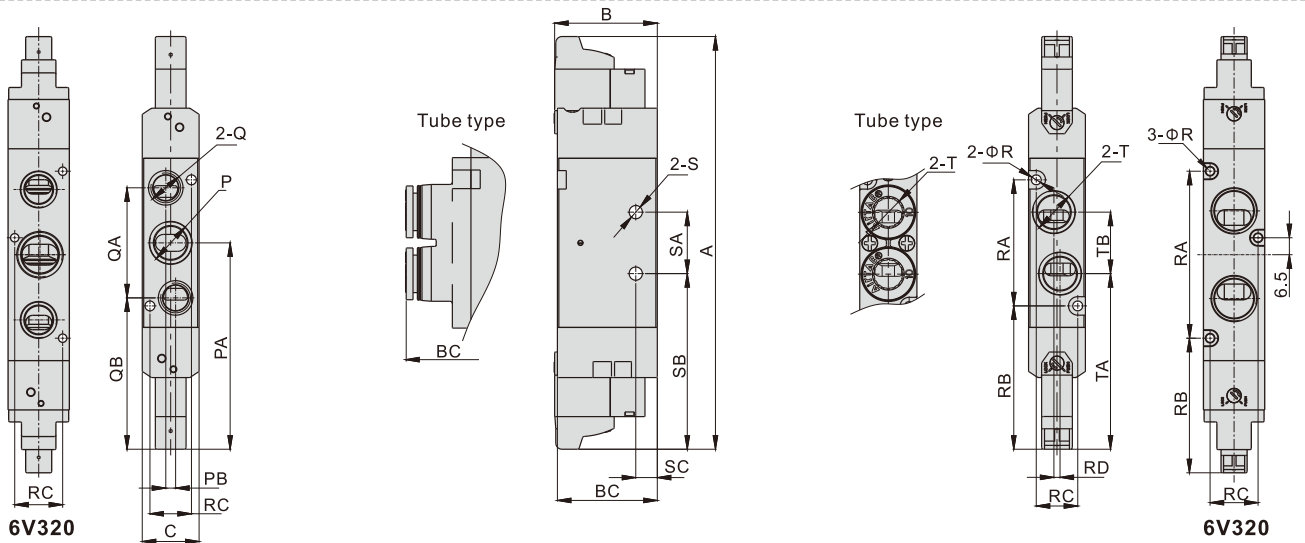

Model/Item	A	B	BC	C	P	PA	PB	Q	QA	QB	T	TA	TB	R	RA	RB	RC	RD	S	SA	SB	SC
6V0520M5	101.5	31	21	10.6	M5X0.8	51	1	M5X0.8	19	41	M5X0.8	45.5	10	2.1	22.5	39.5	7.5	0	Φ2.6	10	45.5	4
6V0520J04			Φ4(Tube)								-								-	-		
6V120M5	121.5	32	24	15.5	M5X0.8	61	2.6	1/8"	28	47	1/8"	52.5	16.5	2.6	34	44	11	0	Φ3.2	14	54	4
6V120J04			Φ4(Tube)								-								-	-		
6V120J06			41								Φ6(Tube)								-	-	-	
6V120J08			42.5								Φ8(Tube)								-	-	-	
6V22006	134	33.5	32.5	18.5	1/8"	67	3.2	1/8"	36	49	1/8"	57	20	3.2	41	46.5	13.5	2	Φ4.3	20	57	7
6V22008			1/4"								-								-	-		
6V220J06			50.6								Φ6(Tube)								-	-	-	
6V220J08			53.5								Φ8(Tube)								-	-	-	
6V220J10											Φ10(Tube)											
6V32010	167	46	46	23.5	3/8"	83.5	0.5	1/4"	50	58.5	3/8"	67	33.5	3.2	64	51.5	18.4	0	Φ4.3	25	71	8

[Note]: The base of the tube type solenoid valve is only used with the base. No through hole "S" on the side.

Solenoid valve (5/2 way, 5/3 way)

Manifold for 6V Series



Specification

Item\Manifold Model	6V0500M	6V100M	6V200M	6V300M
Fluid	Air(to be filtered by 40 μm filter element)			
Temperature °C	-20~70			
Adaptable valve's series	6V0500 Series	6V100 Series	6V200 Series	6V300 Series

Product feature

1. It is available to integrate the direction control valves of the same series to form valve group to save space and cost.
2. It is easy to examine when there are faults owing to the unified air intake and exhaust and unified wiring.
3. Flexible combination and strong expansion capability can make any combination or expansion of the numbers of direction control valves that are connected.

Ordering code

6V100M 5F G Ordering code for manifold



① Model	6V0500M: 6V0500 Series manifold	6V100M: 6V100 Series manifold	6V200M: 6V200 Series manifold	6V300M: 6V300 Series manifold
② Number of stations	1F: 1 Station 2F: 2 Station 3F: 3 Station 20F: 20 Station			
③ Thread type	G: G Thread			

P-6V100M-R2 Ordering code for blank plate



① Model	6V0500M: 6V0500 Series manifold	6V100M: 6V100 Series manifold	6V200M: 6V200 Series manifold	6V300M: 6V300 Series manifold
② Code	R2: Blank plate for manifold			

[Note] 1. Manifold kits contains manifold, seal and screw; 2. Blank plate kits contains blank plate and screw.

Dimensions

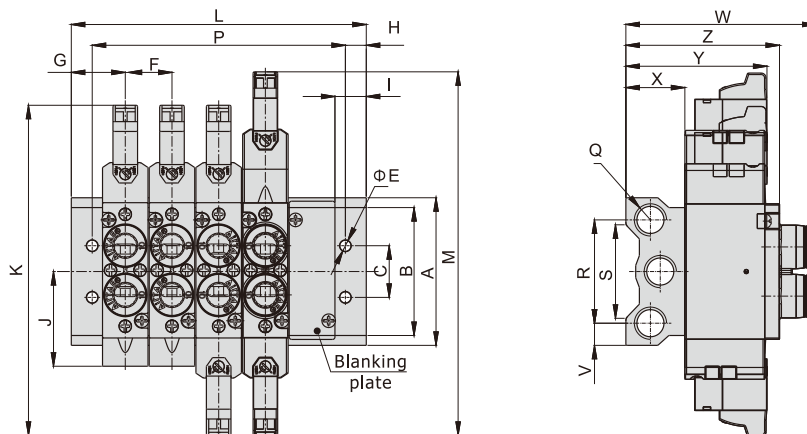

Model\Item	A	B	C	E	F	G	H	I	J	K	M	Q	R	S	V	W			X	Y	Z	
6V0500M	46	32	16	4.5	11	15	5	9.5	22.5	102	110	1/8"	32	26	7	36.2(M5)	50.5(J04)			17	35.5	47.5
6V100M	57.5	43	20	4.5	16	17	5	9.5	33	121.5	133.5	1/4"	40	36	9	55(M5/06)	62.5(J04)/64(J06)	65.5(J08)	22	46	54	
6V200M	60	52	21	4.5	19	18.5	5	9.5	38.5	134.5	148	1/4"	42	38	9	58.5(06/08)	75.2(J06)/76.5(J08)	78.5(J10)	24	57.5	62.5	
6V300M	85	75	26	4.5	23.5	24	5	12	54	167	185	3/8"	57	58	14	-	-	-	27	74	-	

Model\Item	L																			
	1F	2F	3F	4F	5F	6F	7F	8F	9F	10F	11F	12F	13F	14F	15F	16F	17F	18F	19F	20F
6V0500M	30	41	52	63	74	85	96	107	118	129	140	151	162	173	184	195	206	217	228	239
6V100M	34	50	66	82	98	114	130	146	162	178	194	210	226	242	258	274	290	306	322	338
6V200M	37	56	75	94	113	132	151	170	189	208	227	246	265	284	303	322	341	360	379	398
6V300M	48	72	96	120	144	168	192	216	240	264	288	312	336	360	384	408	432	456	480	504

Model\Item	P																			
	1F	2F	3F	4F	5F	6F	7F	8F	9F	10F	11F	12F	13F	14F	15F	16F	17F	18F	19F	20F
6V0500M	20	31	42	53	64	75	86	97	108	119	130	141	152	163	174	185	196	207	218	229
6V100M	24	40	56	72	88	104	120	136	152	168	184	200	216	232	248	264	280	296	312	328
6V200M	27	46	65	84	103	122	141	160	179	198	217	236	255	274	293	312	331	350	369	388
6V300M	38	62	86	110	134	158	182	206	230	254	278	302	326	350	374	398	422	446	470	494

