

Fluid control valve(2/2 way)

2KS Series (Internally piloted and normally opened)

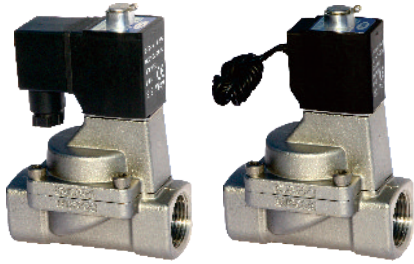

Symbol



Product feature

1. Indirect acting (Internal pilot) and normally opened type 2/2 way solenoid valve. Its can change direction quickly and has large flow.
2. It is compact, small and light weight. It is easy to install and dismantle;
3. The valve body is made of SUS304 . The coil has a Heat resistance classification of Class B. The standard seal material is FPM-F. Please contact us if other material are required.
4. The protection class of the coil is IP65 and there is a choice for grommet or terminal electrical entry .

Inner structure

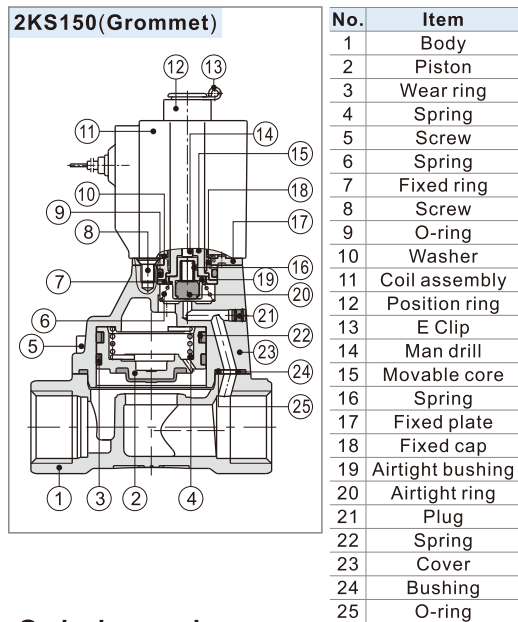

Ordering code

Ordering code of valves

2KS 150 15 A □ G

① ② ③ ④ ⑤ ⑥

① Model	② Orifice size	③ Port size	④ Voltage	⑤ Electrical entry	⑥ Thread type
2KS: 2/2 way internally piloted and normally opened	150: Φ15mm	15: 1/2"	A: AC220V B: DC24V C: AC110V E: AC24V F: DC12V	Blank: Terminal I: Grommet	G: G
	200: Φ20mm	20: 3/4"			
	250: Φ25mm	25: 1"			
	320: Φ35mm	32: 1 1/4"			
	400: Φ40mm	40: 1 1/2"			
500: Φ50mm	50: 2"				

Specification

Model\Item	Port size [Note1]	Orifice size (Φmm)	Cv	Valid area or section (mm ²)	Weight [Note2](g)	Operating pressure differentia		Proof pressure	
						MPa	psi	MPa	psi
2KS150-15	1/2"	15.0	5.50	100.0	680	Max: 0.7 Min: 0.05	Max: 100 Min: 10	1.5	220
2KS200-20	3/4"	20.0	9.50	170.0	880				
2KS250-25	1	25.0	12.50	220.0	1125				
2KS320-32	1 1/4"	35.0	23.00	420.0	2710				
2KS400-40	1 1/2"	40.0	31.00	560.0	3260				
2KS500-50	2"	50.0	49.00	880.0	4310				

[Note1] G thread is available.

[Note2] The weight in the table is the terminal valve's weight, 2KS150~250 series grommet valve's weight is 10g less than terminal's. 2KS320~500 series grommet valve's weight is 20g less than terminal's.

Specification of coil

Valve type	Coil type	Power type	Frequency (Hz)	Voltage range	Electrical entry	Power Consumption (VA/W)	Insulation	Temp. rise(°C)
2KS150 2KS200 2KS250	CDA116 CLA116	AC	50	± 15%	Terminal (CDA)	15.0VA	Class B	50
			60			11.0VA		40
		DC	-	± 10%		6.5W		30
2KS320 2KS400 2KS500	CDA170 CLA170	AC	50	± 15%	Grommet (CLA)	35.0VA		65
			60			30.0VA		60
		DC	-	± 10%		10.5W		40

Valve's specification

Acting	Internally piloted				
	Initial state	Normally opened			
Adaptable fluid	Air, Water, Oil				
Viscosity limit	Under 20CST				
Ambient and fluid temperature (°C)		Water	Air	Oil	Ambient
	Max.	80	90	80	70
	Min.	1	-20 [Note1]	-10 [Note2]	-20

[Note1] Dew point: -20(°C) or less;

[Note2] 50CST or less.

Ordering code of accessories

Ordering code of accessories is the same as 2S series valve's, please refer to P150 for details of ordering code.

[Note] 320\400\500 series valves do not have mounting accessories.

Fluid control valve(2/2 way)

2KS Series (Internally piloted and normally opened)

Flow chart

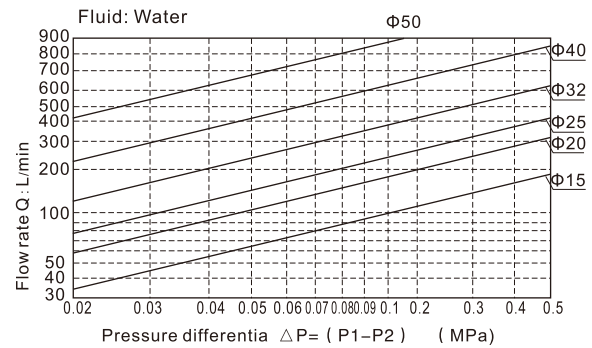
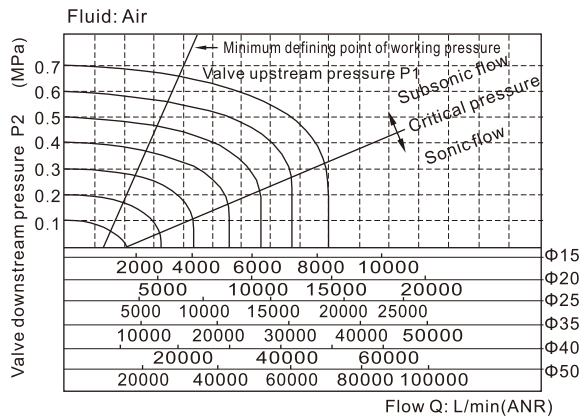

Dimensions

2KS150~250 (Terminal)

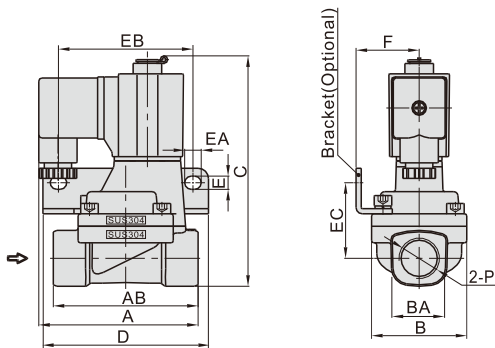

2KS150~250(Grommet)

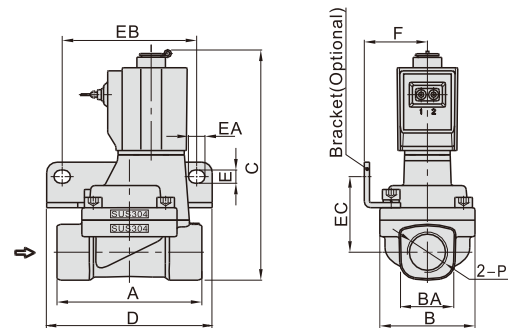

2KS320~500 (Terminal)

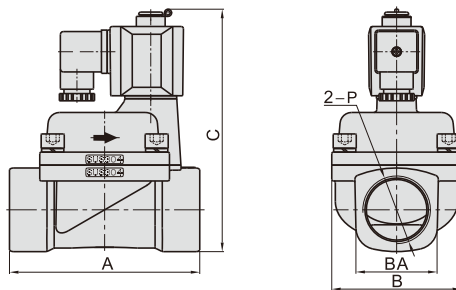

2KS320~500(Grommet)

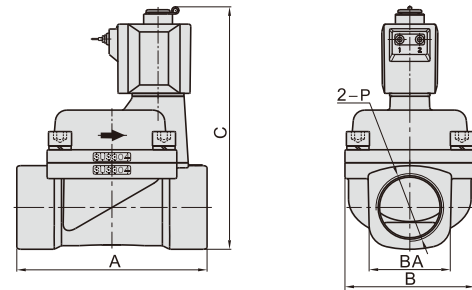

Model\Item	A	AB	B	BA	C	D	E	EA	EB	EC	F	P
2KS150-15	77	70	46	27.5	112.5	80	6.4	8	65	36.5	30.5	1/2"
2KS200-20	78.5	82	53	33.5	121	90	6.4	8	75	40	34	3/4"
2KS250-25	81	92	59	40.5	129.5	95	6.4	8	80	44.5	36	1
2KS320-32	125	-	80	52	160	-	-	-	-	-	-	1 1/4"
2KS400-40	132	-	90	58	167	-	-	-	-	-	-	1 1/2"
2KS500-50	150	-	100	70	182	-	-	-	-	-	-	2"

Model\Item	A	B	BA	C	D	E	EA	EB	EC	F	P
2KS150-15	70	46	27.5	112.5	80	6.4	8	65	36.5	30.5	1/2"
2KS200-20	82	53	33.5	121	90	6.4	8	75	40	34	3/4"
2KS250-25	92	59	40.5	129.5	95	6.4	8	80	44.5	36	1
2KS320-32	125	80	52	160	-	-	-	-	-	-	1 1/4"
2KS400-40	132	90	58	167	-	-	-	-	-	-	1 1/2"
2KS500-50	150	100	70	182	-	-	-	-	-	-	2"