

Fluid control valve(2/2 way)

2KW Series (Internally piloted and normally opened)

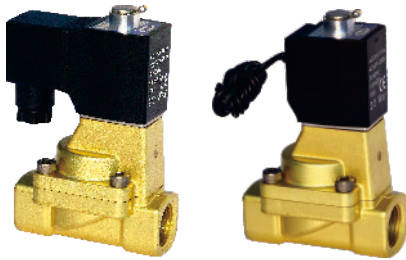

Symbol



Product feature

1. Indirect acting (Internal pilot) and normally opened type 2/2 way solenoid valve. Its can change direction quickly and has large flow.
2. It is compact, small and light weight. It is easy to install and dismantle;
3. The valve body is made of brass . The coil has a Heat resistance classification of Class B. The standard seal material is FPM-F. Please contact us if other material are required.
4. The protection class of the coil is IP65 and there is a choice for grommet or terminal electrical entry .

Inner structure

2KW150 (Terminal)

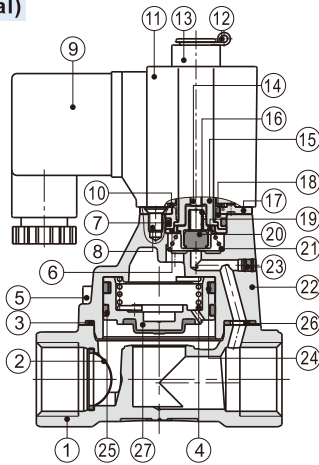

No.	Item	No.	Item	No.	Item
1	Body	10	Washer	19	Airtight bushing
2	Filter	11	Coil assembly	20	Airtight ring
3	O-ring	12	E Clip	21	Spring
4	Spring	13	Position ring	22	Cover
5	Screw	14	Man drill	23	Plug
6	Clip	15	Movable core	24	Bonnet spring
7	O-ring	16	Spring	25	Wear ring
8	Screw	17	Fixed plate	26	Bushing
9	Connector	18	Fixed cap	27	Piston

Ordering code

Ordering code of valves

2KW 150 15 A □ G

① ② ③ ④ ⑤ ⑥

① Model	② Orifice size	③ Port size	④ Voltage	⑤ Electrical entry	⑥ Thread type
2KW: 2/2 way internally piloted and normally opened	150: Φ15mm	15: 1/2"	A: AC220V B: DC24V	Blank: Terminal I: Grommet	G: G
	200: Φ20mm	20: 3/4"	C: AC110V E: AC24V		
	250: Φ25mm	25: 1"	F: DC12V		

Ordering code of accessories

Ordering code of accessories is the same as 2S series valve's, Please refer to P150 for details of ordering code.

Specification

Model\Item	Port size [Note1]	Orifice size (Φmm)	Cv	Valid area or section (mm ²)	Weight [Note2](g)	Operating pressure differentia		Proof pressure	
						MPa	psi	MPa	psi
2KW150-15	1/2"	15.0	5.50	100.0	730	Max: 0.7 Min: 0.05	Max: 100 Min: 10	1.5	220
2KW200-20	3/4"	20.0	9.50	170.0	960				
2KW250-25	1"	25.0	12.5	220.0	1210				

[Note1] G thread is available.

[Note2] The weight in the table is the terminal valve's weight, grommet valve's weight is 10g less than terminal's.

Specification of coil

Valve type	Coil type	Power type	Frequency (Hz)	Voltage range	Electrical entry	Power Consumption (VA/W)	Insulation	Temp. rise(°C)
2KW150	CDA116	AC	50	± 15%	Terminal (CDA)	15.0VA	Class B	50
2KW200	CLA116		60			11.0VA		40
2KW250		DC	-	± 10%	Grommet (CLA)	6.5W		30

Valve's specification

Acting	Internally piloted				
Initial state	Normally opened				
Adaptable fluid	Air, Water, Oil				
Viscosity limit	Under 20CST				
Ambient and fluid temperature (°C)		Water	Air	Oil	Ambient
	Max.	80	90	80	70
	Min.	1	-20 [Note1]	-10 [Note2]	-20

[Note1] Dew point: -20(°C) or less;

[Note2] 50CST or less.

Fluid control valve(2/2 way)

2KW Series (Internally piloted and normally opened)

Flow chart

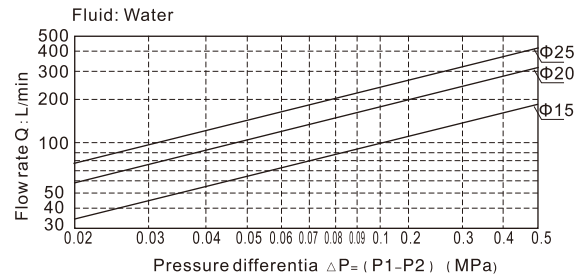
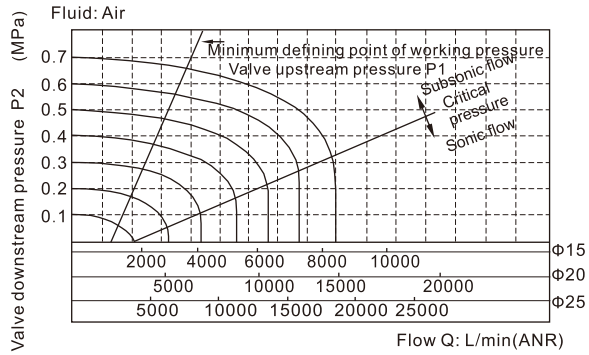

Dimensions

Terminal

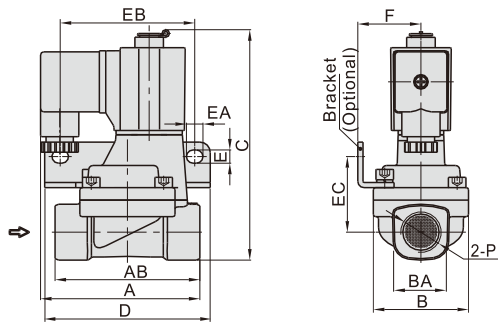

Model\Item	A	AB	B	BA	C	D	E	EA	EB	EC	F	P
2KW150-15	77	70	46	27.5	112.5	80	6.4	8	65	36.5	30.5	1/2"
2KW200-20	78.5	82	53	33.5	121	90	6.4	8	75	40	34	3/4"
2KW250-25	81	92	59	40.5	129.5	95	6.4	8	80	44.5	36	1"

Grommet

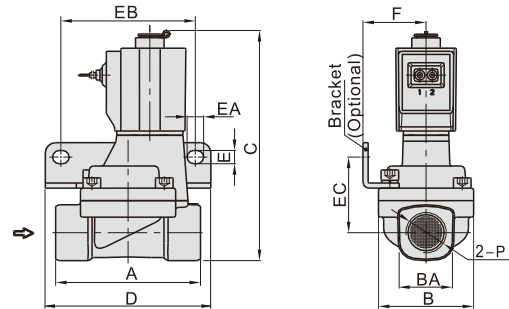

Model\Item	A	B	BA	C	D	E	EA	EB	EC	F	P
2KW150-15	70	46	27.5	112.5	80	6.4	8	65	36.5	30.5	1/2"
2KW200-20	82	53	33.5	121	90	6.4	8	75	40	34	3/4"
2KW250-25	92	59	40.5	129.5	95	6.4	8	80	44.5	36	1"