

MDS Mechanical Pressure Switch



Mechanical pressure switches with adjustable switching output for monitoring the queuing pneumatic or hydraulic pressure



- robust and compact unit
- adjustable switching point
- high precision
- up to 350 bar max. working pressure (more upon request)
- electromechanical signal transducer
- M12 and M3 plug connection per DIN EN 175301-803
- changeover contact function
- long life



Technical Specifications MDS Series

Mediums	self-lubricating fluids like hydraulic oils and lubricants, compressed air		Mounting position	any
			Response	min. velocity of pressure rise 0.01 bar/s
Process connection	G1/8"	G1/4"	Switching point	
Gasket seal	according to DIN3852-E		Accuracy	± 2% of range value at room temperature
Fastening torque	20 Nm	25 Nm	Reproducibility	same as accuracy
Measuring principle	Membrane spring-loaded ≤16 bar,	Plunger spring-loaded ≥ 16 bar	Ambient conditions	
Max. operating pressure	60 bar	350 bar	Temperature range	-20... +80°C
Materials	Membrane: NBR	Plunger: steel	Environment / operation	A-10G / 10-500 Hz
Gasket	---	PTFE, NBR	Vibration resistance	I-100G/6 ms
Housing	Steel, galvanised steel, galvanised		Shock resistance	
Switching output	Changer		Weight	0,15 kg
Number	1			
Switching element	micro switch with silver plated contacts			
Max. switching frequency	100/min			
Switching power with plug	M3	M12		
DC to 28 V	2 A	2 A		
AC to 250 V	4 A	---		

Switch-back difference

Membrane Type

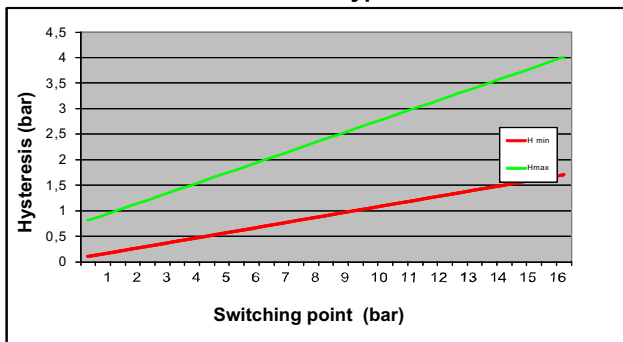

Plunger type

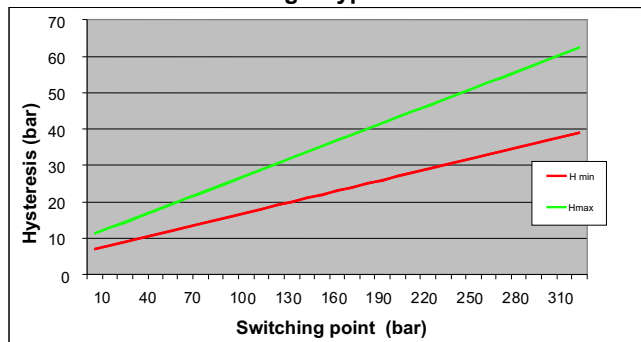

Plug connection	M3 (DIN EN 175301-803) 3 pol. + PE 250V IP65 PG9	M12 (socket) 4 pol. 28V IP67**
Max. voltage		
Protection class		
Cable fitting		**when connected
Pin assignment		

Dimensions

Version M3

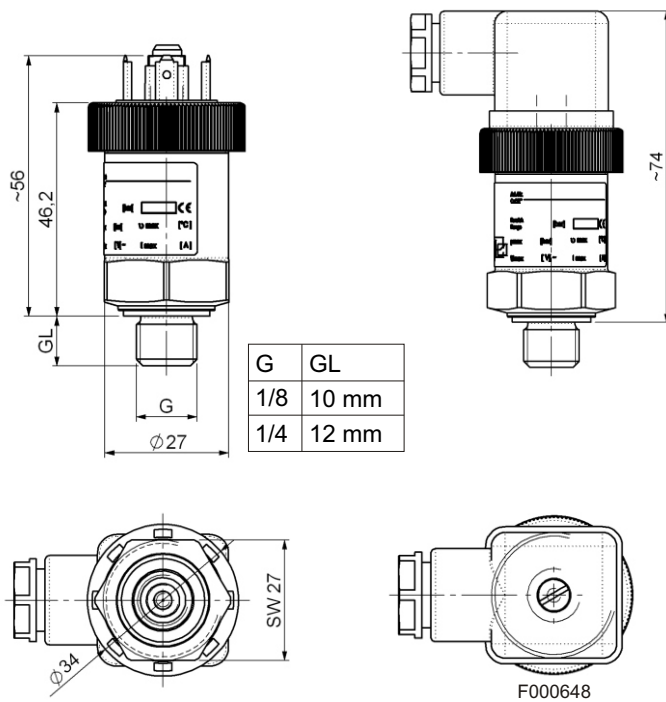

Version M12

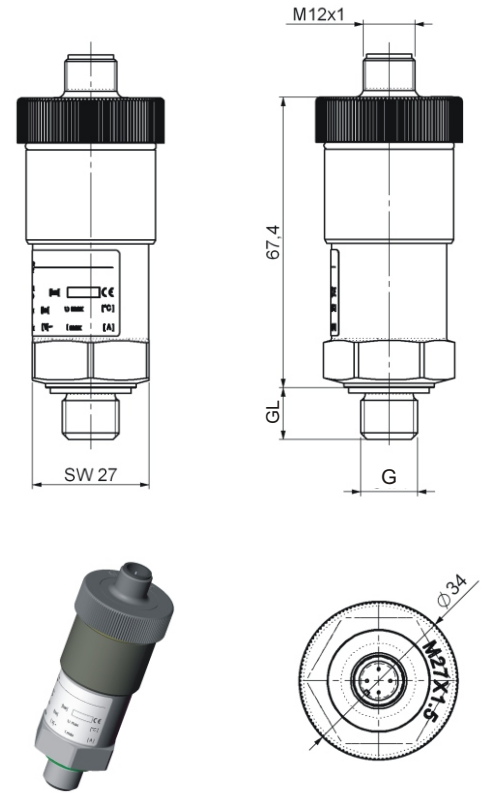

Accessories: Part no.: 9144050047 Connecting cable M12x1, 4-pin, L = 5m
 Part no.: 9146100159 Contact box M12x1, 90° angle

Product code for MDS

MDS - - - -

Model		Pressure ranges Pressure point setting ¹⁾ (optional)
Connector M3 or M12		Pressure ranges
Fluid Port G1/8" or G1/4"		8: 0,5...8 bar Membrane pressure switch
		16: 1...16 bar Membrane pressure switch
		120: 10...120 bar Piston pressure switch
		250: 20...250 bar Piston pressure switch
		320: 30...320 bar Piston pressure switch

¹⁾ If necessary the switching point can be set by the supplier. The switching point must be set for rising or falling pressure, i.e. switching point monitoring of 0 bar to switching point (rising) or from max. operating pressure decreasing to switching point (falling). Refer to the following example for the circuitry:

MDS-M3-G1/4-120-80R (switching point 80 bar rising)
 PIN3-2 closed when switching point is reached

MDS-M3-G1/4-120-80F (switching point 80 bar falling)
 PIN3-1 closed when switching point is reached

Technical Specifications MDSM & MDSK Series

	MDSM	MDSK
Mediums	Neutral fluids, compressed air	self-lubricating fluids such as hydraulic oils and lubricants
Process connection	G1/4" inside	G 1/4" rotary, vertical flange DIN ISO 16873 Fastening torque: 25 Nm
Mounting position	any	any
Measuring principle	Spring-loaded membrane	Spring-loaded piston
Max. operating pressure	60 bar	350 bar
Min. velocity of pressure rise	0,01 bar/s	0,01 bar/s
Switching point		
Accuracy/reproducibility	± 2% of range value at room temperature	± 2% of range value at room temperature
Materials		
Measuring element	membrane: NBR	piston: stainless steel 1.4305
Pressure connection	zinc die cast (G1/4" inside)	galvanised steel (G1/4" rotary), zinc die cast (vertical flange)
Housing	zinc die cast	zinc die cast
Switching output		
Number	Changer 1, adjustable with lock	Changer 1, adjustable with lock
Switching element	micro switch with silver plated contacts	micro switch with silver plated contacts
Max. switching frequency	200 / min.	200 / min.
Max. switching power		
with plug	M3 M12	M3 M12
DC to 28V	3 A 3 A	3 A 3 A
AC to 250V	6 A ---	6 A ---
Ambient conditions		
Temperature range		
Environment/operation	-10 °C...+80 °C	-10 °C...+80 °C
Vibration resistance	A-10G/10-500 Hz	A-10G/10-500 Hz
Shock resistance	I-100G/6 ms	I-100G/6 ms
Weight	0,3 kg	0,33 kg

Switch-back difference:

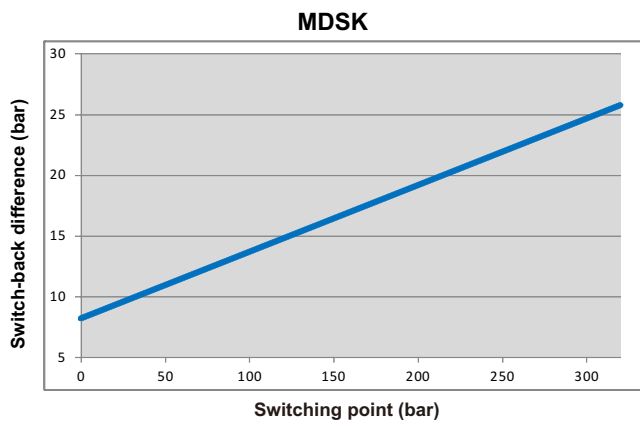
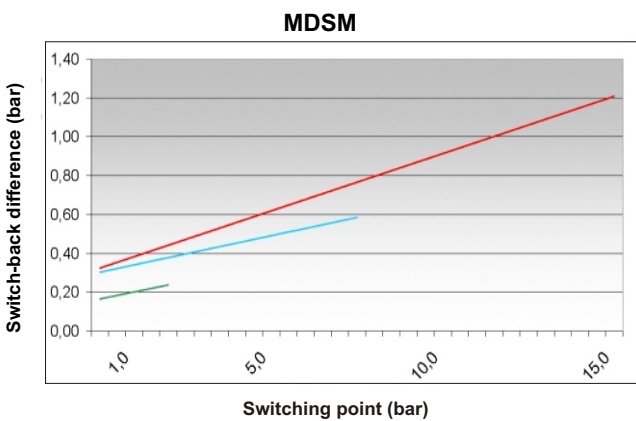

Plug connection	M3 (DIN EN 175301-803) 3 pol. + PE	M12 (Socket) 4 pol.
Max. voltage	250V	28V
Protection class	IP65	IP67**
Cable fitting	PG9	
		**when connected
Pin assignment		

Dimensions

MDSM

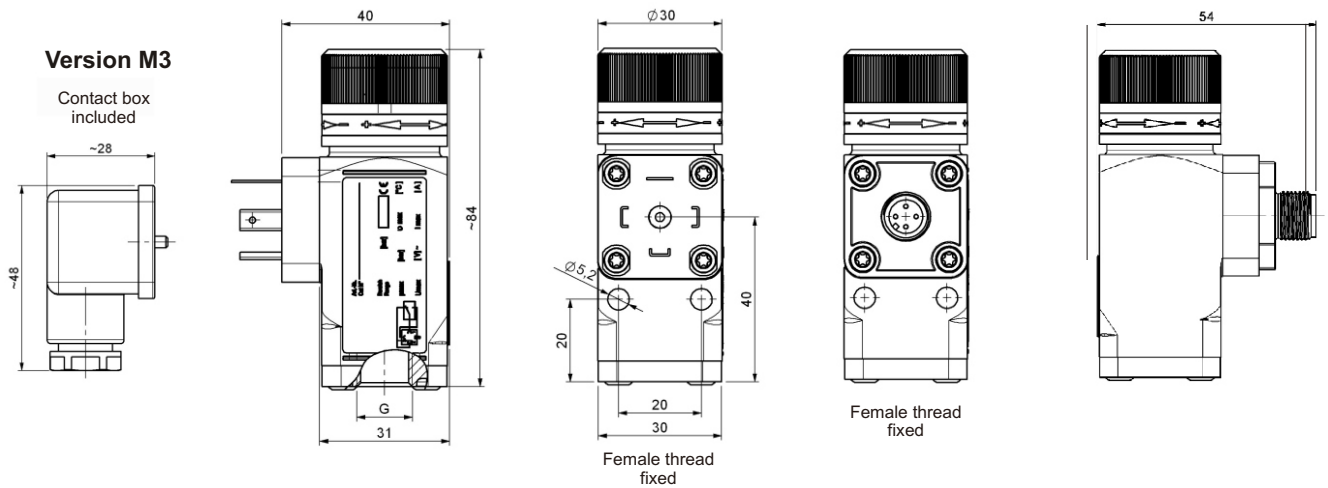

MDSK

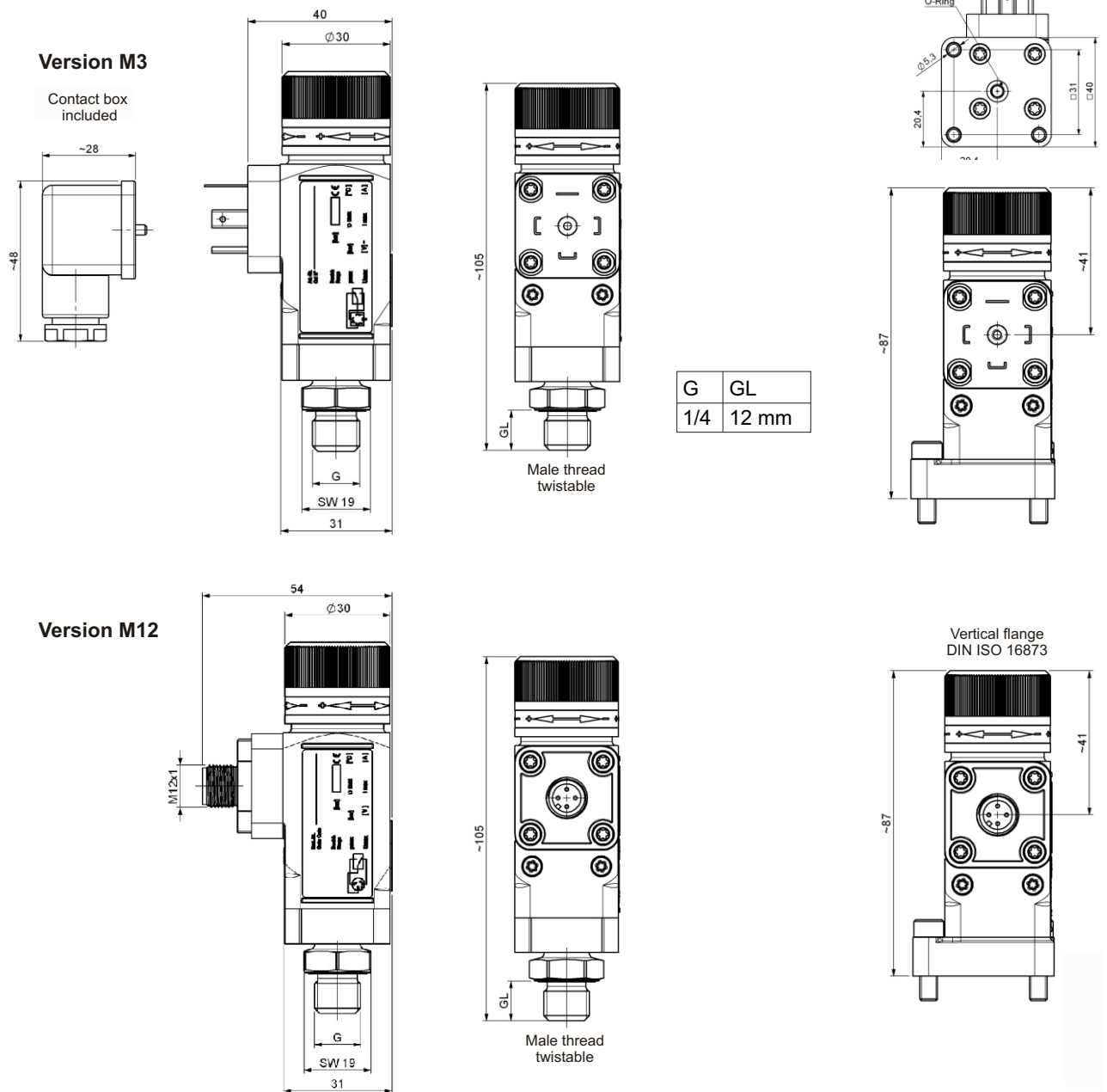

Accessories:
 Art-Nr.: 9144050047 Connecting cable M1 2x1, 4-pin plug, L = 5m
 Art-Nr.: 9146100159 Contact box M1 2x1, 90° angle
 Art-Nr.: 9008429 Double nipple G1/4, stainless steel

Product code

MDS - - - -

Model

M MDSM
K MDSK

Plug connection

M3 or M12

G1/4i G1/4" inside (MDSM only)
G1/4d G1/4" twistable (MDSK only)
VF Vertical flange per ISO 16873 (MDSK only)

Pressure ranges

Pressure point setting ¹⁾

Pressure ranges

8 :	0,5...8 bar	MDSM
16:	1...16 bar	MDSM
120:	10...120 bar	MDSK
250:	20...250 bar	MDSK
320:	30...320 bar	MDSK

¹⁾ If necessary the switching point can be set by the supplier. The switching point must be set for rising or falling pressure, i.e. switching point monitoring of 0 bar to switching point (rising) or from max. operating pressure decreasing to switching point (falling). Refer to the following example for the circuitry:

MDSK-M3-G1/4-120-80R (switching point 80 bar rising)
 PIN1-3 closed when switching point is reached

MDSK-M3-G1/4-120-80F (switching point 80 bar falling)
 PIN1-2 closed when switching point is reached